

NOTES: (unless otherwise specified)

1. ASSEMBLY WEIGHT: 0.32 LBS. ± 10%
2. HARNESS OMITTED FROM SOME VIEWS FOR CLARITY
3. CONNECTOR: 9 PIN MALE D-SUB
MATE: 9 PIN FEMALE D-SUB
MATING CONNECTOR KIT (0300-022) INCLUDED
4. REFER TO OUTLINE & INSTALLATION DRAWING OF MONITOR ASSEMBLY FOR SPECIFIC PINOUT INFORMATION

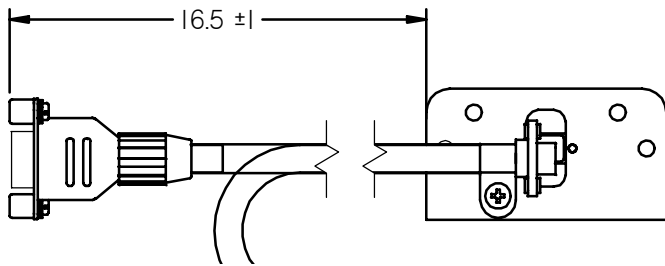
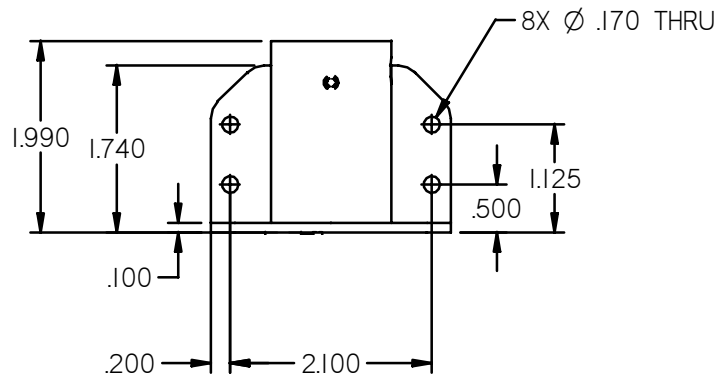
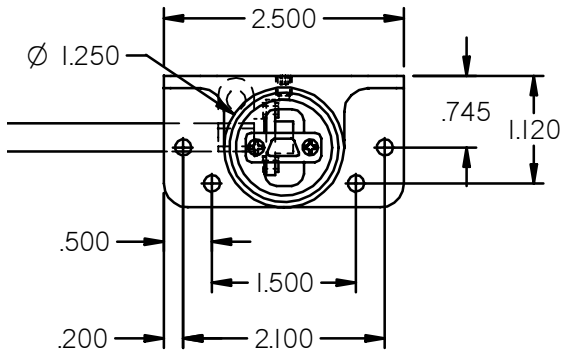

REVISIONS

ZONE	REV	DESCRIPTION	DATE	BY	CHG NO	APRV
	A	INITIAL DRAWING RELEASE	05/19/09	GJH	ECO9098	

ELECTRONIC REVISION CONTROLLED

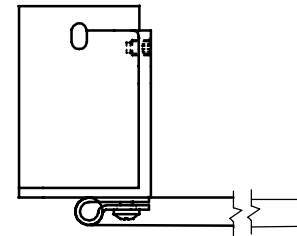
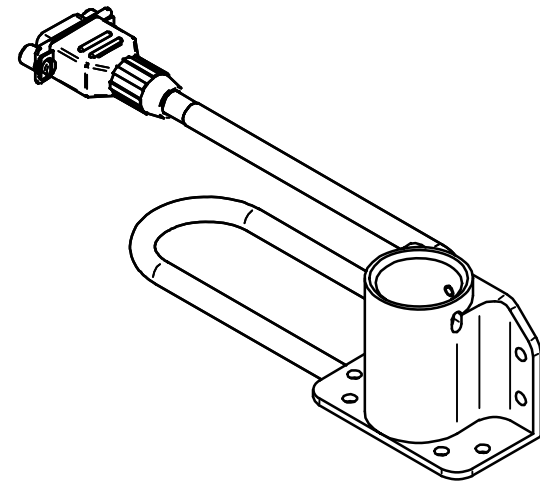

THE INFORMATION CONTAINED HEREIN IS PROPRIETARY TO ROSEN AVIATION, LLC. IT SHALL NOT BE REPRODUCED OR DISCLOSED IN WHOLE OR IN PART OR USED FOR ANY DESIGN OR MANUFACTURE EXCEPT WHEN SUCH USER POSSESSES DIRECT, WRITTEN AUTHORIZATION FROM ROSEN AVIATION. THIS DRAWING MAY BE COVERED UNDER ONE OR MORE U.S. OR INTERNATIONAL PATENTS. PLEASE CONTACT ROSEN AVIATION FOR SPECIFIC INFORMATION.

Rosen Aviation
 1020 OWEN LOOP SOUTH
 EUGENE, OREGON 97402
 TEL: (541) 342-3802 FAX: (541) 342-4912

TITLE
**OUTLINE & INSTALLATION DRAWING,
 MICRO-D, STANDARD BODY**

FIRST CALLED FOR: (FCF)

SLIMLINE BASE RECEPTACLE

APPROVALS	INITIAL	DATE
DRAWN BY	GJH	03/23/09
CHECKER	SC	05/19/09
ENGINEER	DRF	05/19/09

DWG NO
 0100-002-CD

SIZE	REV
A	A

SCALE 1:2 SHEET 1 OF 1

UNLESS OTHERWISE SPECIFIED DIMENSIONS ARE IN INCHES
 .XX = ± .03
 .XXX = ± .010

 = ± 2.0°
 INTERPRET DIM AND TOL PER ASME Y14.5M - 1994